

LÍNEA COMERCIO

Hervidor De Agua 20 Ltros

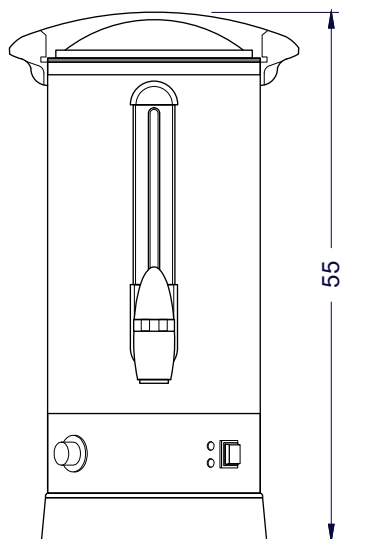

Vista Elevación

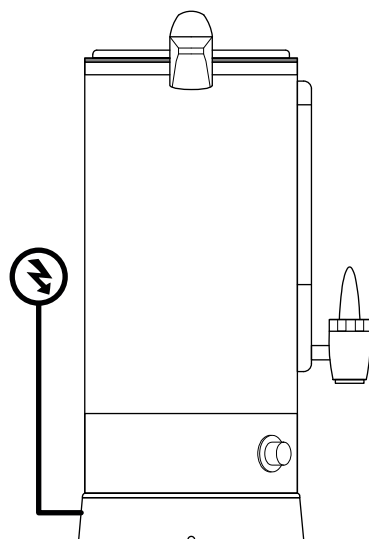

Vista Izquierda

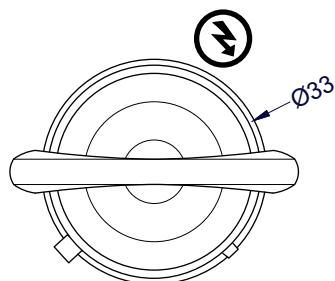

Vista Planta

Unidad: cm

TIERRAS BAJAS

EQUIPAMIENTO COMERCIAL

Características

- Cuerpo y Tapa en acero inoxidable.
- Indicadores de encendido y en funcionamiento.
- Resistencia 220V / 50Hz
- 85° C Temperatura máxima.
- Capacidad: 20 Lts.
- Dimensiones (mm): 330x330x550
- Consumo: 2500 W
- Peso: 5,4 KG.

	Capacidad	Neto 20 litros	
	Dimensiones equipo	Ancho Ø33 cm	Alto 55 cm
	Peso	Neto 5,4 kg	
	Especificaciones eléctricas	Consumo 2500W	Energía 220V/50Hz
	T° de trabajo	85°C	