

LÍNEA FRÍO

Vitrina barquillera 9 sabores

KATHY-9

Equipo ideal para mantención y exhibición de productos



*Imagen referencial

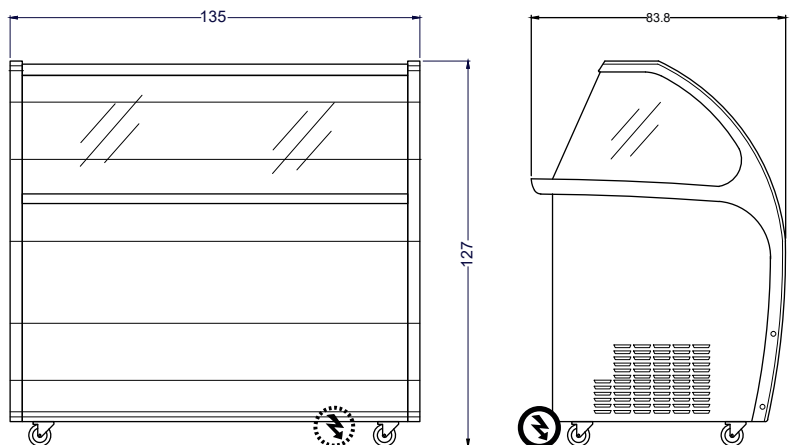

Vista Elevación

Vista Izquierda

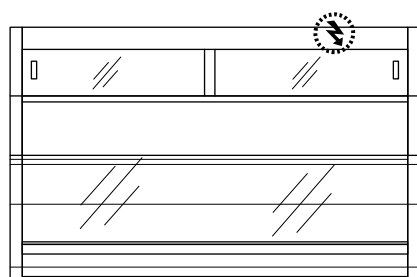

Vista Planta

Unidad: cm

TIERRAS BAJAS

EQUIPAMIENTO COMERCIAL

Características

- Barquillera con capacidad para 9 sabores. Incorpora separadores interiores que permiten trabajar tanto helado en caja como en bachas (no incluye bachas).
- Repisa de vidrio intermedio, tapa de vidrio semi curvo superior, y puerta corredera trasera.
- Bodega trasera, la que facilita el almacenaje del helado.
- Luz frontal e iluminación LED en el interior.
- Incluye termómetro para control de temperatura.
- Permite incorporar gráfica tanto frontal como en sus costados.
- Incluye ruedas, lo que permite un fácil desplazamiento.

	Capacidad	9 sabores	Neta 310 litros	Bruta 415 litros
---	-----------	------------------	---------------------------	----------------------------

	Dimensiones	Ancho 135 cm	Profundidad 83.8 cm	Alto 127 cm
---	-------------	------------------------	-------------------------------	-----------------------

	Peso	Peso Neto 123 kg	Peso Bruto 162 kg	
---	------	----------------------------	-----------------------------	--

	Especificaciones eléctricas	Potencia 0.297kW	Energía 220V/50Hz	Consumo 3.75 kW/24h
---	-----------------------------	----------------------------	-----------------------------	-------------------------------

	Refrigerante	R134a/ 285g		
---	--------------	--------------------	--	--

	T° de trabajo	-18°C		
---	---------------	--------------	--	--